

PORTOBOMBAS



60 Hz



DOC - DIWA - DOMO DOMO GRI - DN - DL Series

DRAINAGE AND SEWAGE
ELECTRIC PUMPS



Rua Senhor do Bom Fim, 708 - PORTO ALEGRE - RS FONE/FAX: +55 (51) 3350.8878 (51) 3350.5687
e-mail: contato@portobombas.com.br site: www.portobombas.com.br



xylem
Let's Solve Water



**Submersible
Electric
Pumps for
Solid-laden
Wastewater**

DOMO Series



The DOMO series electric pumps are available with **twin-channel** or **vortex** impeller (DOMO VX). Designed to handle suspended solids up to 50 mm in diameter (35 mm for DOMO 7 and DOMO 7VX). Four basic versions with 0.55 (0.75 HP) to 1.5 kW (2HP) rated power.

DRIVELUB SEAL SYSTEM.



APPLICATIONS

- Pumping of effluent (VX versions can also handle suspended solids).
- Emptying of septic tanks and residential sumps.
- Draining of flooded basements and garages.

SPECIFICATIONS

- **Continuous duty** with 35°C liquids and fully submerged pump.
- **Dry motor** (class F insulation).
- **H07RN-F** type neoprene power cord.
- **Maximum immersion depth: 5 m.**
- Versions:
Single-phase 220 V 60 Hz 2 poles.
Three-phase 380 V 60 Hz 2 poles.
 Other voltages are available on request.
- **Motor power 0.55 to 1.1 kW for single-phase versions. 0.55 to 1.5 kW for three-phase versions.**
- The single-phase versions feature: **Pre-assembled float** (version without float available on request).

Integrated capacitor (except for DOMO 15 and DOMO 15 VX with control box on cable).

Thermal overload protection.

- The **DOMO 7** and **DOMO 7VX** versions feature:
 - Rp 1 1/2" **delivery port** (female gas).
 - Handling of suspended **solids up to 35 mm** in diameter.
 - **Fiberglass-reinforced nylon impeller** (stainless steel impeller also available).
- The **DOMO 10-15-20** and **DOMO 10-15-20 VX** versions feature:
 - **2" delivery port**, female gas (can be turned into a flanged version if an optional accessory is installed).
 - Handling of suspended **solids up to 50 mm** in diameter.
 - **Stainless steel twin-channel or vortex impeller.**

DRIVELUB SEAL SYSTEM

- Watertight electric motor protected by multiple seal system with **oil chamber**. A V-ring and **silicon carbide mechanical seal** (extremely resistant to wear and abrasion), as well as a **lip seal** which is continuously lubricated thanks to the **DRIVELUB system**, provide an extremely efficient barrier against infiltration.

TABLE OF MATERIALS

PART	MATERIAL
Pump body, Motor casing	STAINLESS STEEL (ANSI 304 - DIN 1.4301)
DOMO 7 (VX) impeller	FIBERGLASS-REINFORCED NYLON
DOMO 10-15-20 (VX) impeller	STAINLESS STEEL (ANSI 304 - DIN 1.4301)
Lower mechanical seal	SILICON CARBIDE/ SILICON CARBIDE
Upper lip seal	NITRILE RUBBER
Shaft extension	STAINLESS RUBBER (ANSI 304 - DIN 1.4301)
Handle	NYLON





**DOMO SERIES
OPERATING CHARACTERISTICS AT 3450 rpm, 60 Hz**

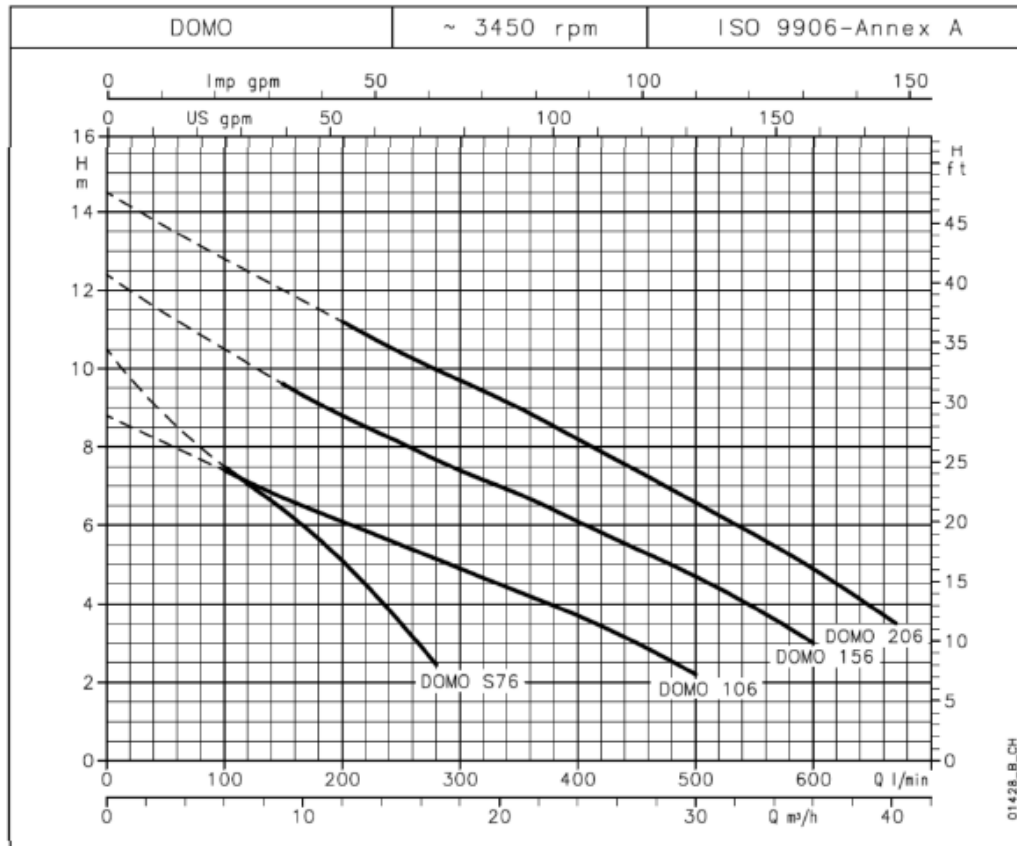

HYDRAULIC PERFORMANCE TABLE AT 60 Hz

PUMP TYPE	RATED POWER		Q = DELIVERY												
			l/min	0	100	150	200	250	280	350	400	500	600	670	
			m³/h	0	6	9	12	15	16,8	21	24	30	36	40,2	
			H = TOTAL HEAD METRES COLUMN OF WATER												
DOMO S76(T) - DOMO S76 GT	0,55	0,75	10,5	7,5	6,4	5,1	3,5	2,4	-	-	-	-	-	-	
DOMO106(T) - DOMO106 GT	0,75	1	8,8	7,4	6,7	6,1	5,5	5,1	4,3	3,7	2,2	-	-	-	
DOMO156(T) - DOMO156 GT	1,1	1,5	12,4	-	9,6	8,8	8,1	7,7	6,8	6,1	4,7	3	-	-	
DOMO206T	-	1,5	14,5	-	-	11,2	10,4	10	9	8,2	6,6	4,9	3,5	-	

These performances are valid for liquids with density $\rho = 1.0\text{kg/dm}^3$ and kinematic viscosity $\nu = 1\text{mm}^2/\text{sec}$

domo-2p60-en_a_th

ELECTRICAL DATA (60 Hz, 3450 rpm) DOMO SERIES

PUMP TYPE	INPUT POWER*	INPUT CURRENT* 220-230 V	CAPACITOR
DOMO S76 - DOMO S76 GT	0,84	4,21	20
DOMO106 - DOMO106 GT	1,1	5,39	22
DOMO156 - DOMO156 GT	1,56	7,03	30
-	-	-	-

PUMP TYPE	INPUT POWER*	INPUT CURRENT* 220-230 V	INPUT CURRENT* 380-400 V
DOMO S76T	0,73	-	1,32
DOMO106T	1,05	-	1,97
DOMO156T	1,45	-	2,54
DOMO206T	1,79	-	3,23

*Maximum value in specified range
(1) Available on request

domo-2p60-en_a_te



Rua Senhor do Bom Fim, 708 - PORTO ALEGRE - RS FONE/FAX: +55 (51) 3350.8878 (51) 3350.5687
e-mail: contato@portobombas.com.br site: www.portobombas.com.br





**DOMO SERIES
DIMENSIONS AND WEIGHTS**

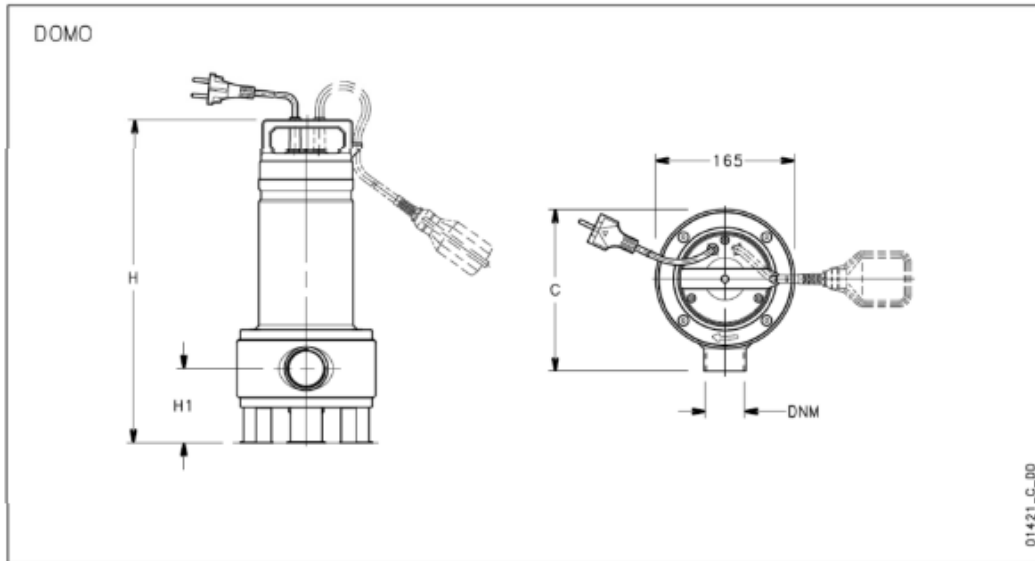

PUMP TYPE SINGLE-PHASE		DIMENSIONS (mm)			DNM	WEIGHT kg
		H	H1	C		
DOMO S76	DOMO S76 GT	433	88	193	Rp1½	11
DOMO S76VX	DOMO S76VX GT					
DOMO106	DOMO106 GT	463	111,5	198	Rp2	13
DOMO106VX	DOMO106VX GT					
DOMO156	DOMO156 GT	463	111,5	198	Rp2	15
DOMO156VX	DOMO156VX GT					
-	-	-	-	-	-	-

PUMP TYPE THREE-PHASE		DIMENSIONS (mm)			DNM	WEIGHT kg
		H	H1	C		
DOMO S76T	DOMO S76VXT	386	88	193	Rp1½	10
DOMO106T	DOMO106VXT	433	111,5	198	Rp2	11
DOMO156T	DOMO156VXT	463	111,5	198	Rp2	13
DOMO206T	DOMO206VXT	463	111,5	198	Rp2	14

domo 3p60 en_a_td

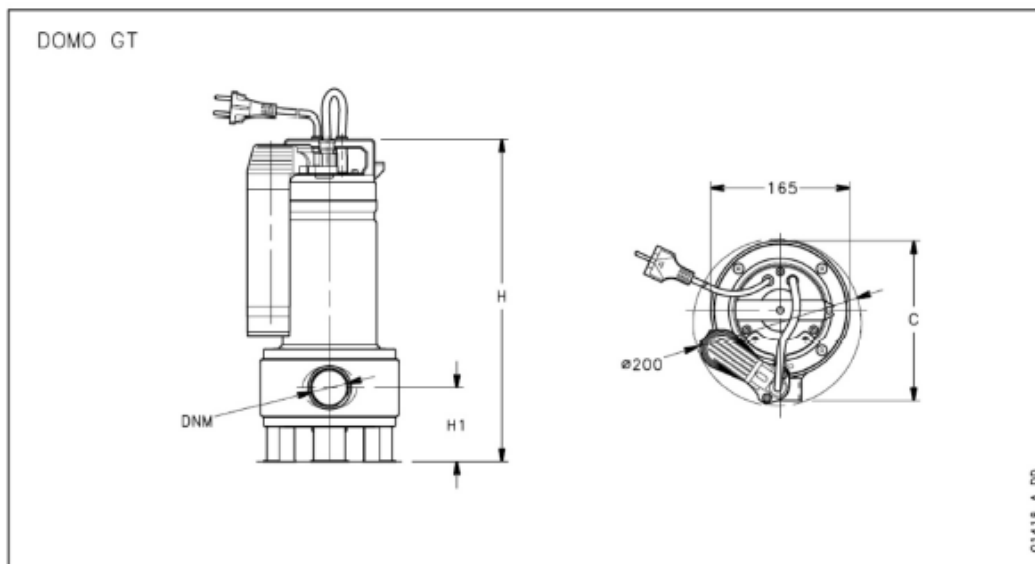

Rua Senhor do Bom Fim, 708 - PORTO ALEGRE - RS FONE/FAX: +55 (51) 3350.8878 (51) 3350.5687
 e-mail: contato@portobombas.com.br site: www.portobombas.com.br

